

## Features

- Utilizes a CREE XHP50 LED
- Maximum output up to 2150 lumens
- High efficiency circuit board provides up to 810 hours runtime
- Boasts a peak beam intensity of 53,300cd and a throw distance up to 462 meters
- Five brightness levels and three special modes to select from
- A micro-textured reflector offers wide angle lighting
- Featuring Advanced Temperature Regulation (ATR) technology to dynamically adjust output performance according to its internal temperature
- Direct access to ultralow and turbo modes
- Innovative dual switch offers user-friendly interface
- Integrated power indicator light displays remaining battery power ( Chinese Patent:ZL201220057767.4)
- Reverse polarity protection prevents damage from incorrectly inserted batteries
- Stainless steel retaining ring protects core components from damage
- Toughened ultra-clear mineral glass with anti-reflective coating
- Constructed from aerospace grade aluminum alloy
- Robust HAIII military grade hard-anodized
- Waterproof in accordance with IPX-8 (two-meter submersible)
- 1 meter impact resistance
- Tail stand capability

## Dimensions

Length: 193mm (7.6")  
 Head diameter: 60mm (2.36")  
 Tube diameter: 41.8mm (1.65")  
 Weight: 282g (9.95oz)(without battery)

## Accessories

Quality holster, lanyard,  
 spare O-ring

## Battery Options

	TYPE	Nominal voltage	Compatible
Primary AA battery	AA	1.5V	Y (Recommended)
Rechargeable AA battery	AA	1.2V	Y (Recommended)
Primary AA Lithium battery	L91	1.5V	Y
Rechargeable Li-ion battery	14500	3.7V	N (Banned)

## Output & Runtime

FL1 STANDARD	TURBO	HIGH	MID	LOW	ULTRALOW	STROBE	SOS	LOCATION
	2150 LUMENS	1200 LUMENS	460 LUMENS	80 LUMENS	1 LUMEN	2150 LUMENS	2150 LUMENS	2150 LUMENS
	1h45min	2h30min	7h	32h	810h	—	—	—
	462m	345m	208m	77m	5.5m	—	—	—
	53300cd	29800cd	10800cd	1500cd	8cd	—	—	—
	1m (Impact Resistant)							
	IPX8, 2m (Waterproof and Submersible)							

## NOTICE

The above data has been measured in accordance with the international flashlight testing standards ANSI/NEMA FL1 using 8 x 1.2V 2450mAh AA batteries under laboratory conditions. The data may vary slightly during real-world use due to battery type, individual usage habits and environmental factors.

## Operation Instructions

### Battery Installation

1. Insert batteries with the positive (+) and negative (-) ends corresponding to the diagram on the inside of the battery compartment.
2. Tighten the tailcap by aligning the two gold pins on the inside of the tailcap with the corresponding holes on the flashlight bottom and rotating clockwise.

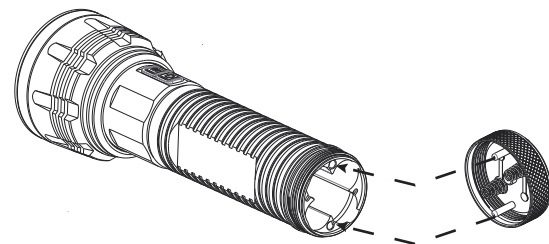
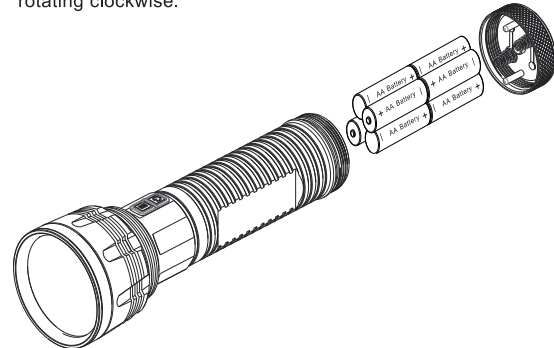

### Tips

Inserting batteries in a dark environment: Two of the four battery slots in the EA81's battery compartment feature grooves indicating that batteries should be inserted with the negative (-) ends facing forward, while the two slots with no grooves require the batteries to be inserted with the positive (+) ends facing forward. In this way, batteries can be inserted correctly through tactile feedback alone.

Upon loading the batteries, the power indicator light will blink to indicate the battery power. Please refer to the "Power Tips" section of this manual for details.

### WARNING

1. Do not mix rechargeable with non-rechargeable batteries.
2. Do not mix batteries of different types/brands.

### On/Off Operation

To turn on: press the on/off switch to turn the light on  
 To turn off: press the on/off switch again to turn the light off

### Standby Mode

With the light turned on, press and hold the on/off switch for more than one second to turn off the light and activate location beacon function. The blue power indicator will flash once every three seconds to indicate the location of the EA81. In this mode, the EA81 can keep running on 8 x AA batteries for 1 year.

**NOTE:** With the power indicator off in standby mode, the EA81 can stay in standby mode for 2 years with 8 x AA batteries.

### Brightness Levels

With the light turned on, press the mode switch to cycle through brightness levels of ultralow, low, medium, high and turbo. The EA81 has memory effect. When it is switched on, the EA81 will enter the brightness

# NITECORE®

The All-Round Flashlight Expert



level last used.

## Instant Ultralow/Turbo

Instant ultra-low: with the light turned off, press the on/off switch  for more than one second to ultralow (1 lumen);

Instant turbo: with the light turned off, press the mode switch  for more than one second to enter turbo (2150 lumens).

## Special Modes (Strobe/Location/SOS)

With the light turned on, press the mode switch  for more than one second to enter strobe mode. To cycle through all three modes of Strobe / Location / SOS, simply press the mode switch  for more than one second again. To exit special modes, simply press the on/off switch .

### Strobe ready

With the light turned off, press the mode switch  twice in quick succession to enter strobe mode instantly. To exit, simply press any button and the light will be turned off.

## Lockout/Unlock

With the light turned on, press and hold both switches for more than one second until the flashlight is switched off and enters lockout mode. In this mode, the EA81 can continue working on 8 × AA batteries for over 2 years.

Lockout mode prevents accidental activation of the flashlight. To exit lockout mode, simply press and hold both switches for more than one second again.

### NOTE:

When the EA81 is kept in a backpack or left unused for extended periods, Nitecore recommends removing the batteries to cut off power, thus preventing parasitic battery drain or accidental activation of the flashlight.

## Power Tips

Each time batteries are inserted, or the mode switch is pressed with EA81 turned off, the blue LEDs will blink to indicate battery levels:

1. Three times for battery levels over 50%;
2. Twice for battery levels below 50%;
3. Once for battery levels close to depletion (below 10%).

## ATR Technology

Advanced temperature regulation (ATR) technology allows EA81 to dynamically adjust output performance based on its internal temperature. This prevents damage from overheating and prolongs its working life.

## Changing Batteries

Batteries should be replaced when any of the following occurs: The output appears to be dim or the flashlight becomes unresponsive.

## Maintenance

Every 6 months, threads should be wiped with a clean cloth followed by a thin coating of silicon-based lubricant.

## Warranty Service

All NITECORE® products are warranted for quality. Any defective / malfunction NITECORE® product can be repaired free of charge for a period of 60 months (5 years) from the date of purchase. Beyond 60 months (5 years), a limited warranty applies, covering the cost of labor and maintenance, but not the cost of accessories or replacement parts.

The warranty is nullified in all of the following situations:

1. The product(s) is/are broken down, reconstructed and/or modified by unauthorized parties.
2. The product(s) is/are damaged through improper use.
3. The product(s) is/are damaged by leakage of batteries.

For the latest information on NITECORE® products and services, please contact a local NITECORE® distributor or send an email to [service@nitecore.com](mailto:service@nitecore.com)

※All images, text and statements specified herein this user manual are for reference purpose only. Should any discrepancy occurs between this manual and information specified on [www.nitecore.com](http://www.nitecore.com), information on our official website shall prevail. Sysmax Industry Co., Ltd. reserves the rights to interpret and amend the content of this document at any time without prior notice.

 Please find us on facebook: NITECORE Flashlight

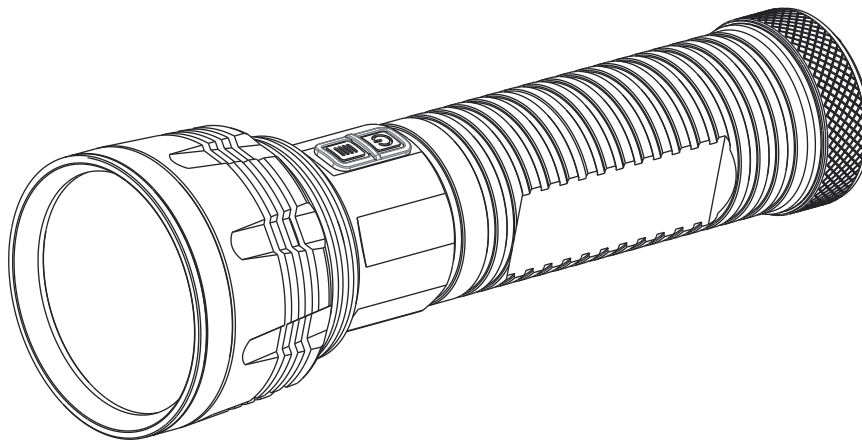

**SYSMAX ind.**

SYSMAX Industry Co., Ltd.

TEL: +86-20-83862000

FAX: +86-20-83882723

E-mail: [info@nitecore.com](mailto:info@nitecore.com)

Web: [www.nitecore.com](http://www.nitecore.com)

Address: Rm 2601-06, Central Tower, No.5 Xiancun Road, Tianhe District, Guangzhou, 510623, Guangdong, China



Made in China

Thanks for purchasing NITECORE!